

AC Front End

FE175D480x033FP-00



Overview

- Universal Input: 85 – 264V_{AC}
- Output: 48V_{DC} - isolated, regulated (SELV)
- Power: 330W - over entire input voltage range
- Isolated AC-DC converter with active Power Factor Correction (PFC)
- Integrated rectification, filtering and transient protection
- Peak efficiency: >92%
- EN55022, Class B EMI conducted emissions with a few components
- EN61000-3-2 harmonic limits
- –40 to 100°C baseplate operation.



Features & Benefits

- Compact and robust package
 - Low profile, 9.55mm height above board
 - Small footprint
 - Flanged aluminum package for secure mounting and thermal management
- Consistent high efficiency across the worldwide mains (flat efficiency curve)
- Integrated solution streamlines design, reduces time to market
 - Module includes PFC, regulation, isolated 48V output (SELV), filtering, rectification, transient protection, agency approvals, simplified thermal management
 - Simple design, requires few external components
- Full-feature module with high power density
 - Module power density, 121W/in³
 - Complete solution including hold-up capacitors, 54W/in³

Typical Application

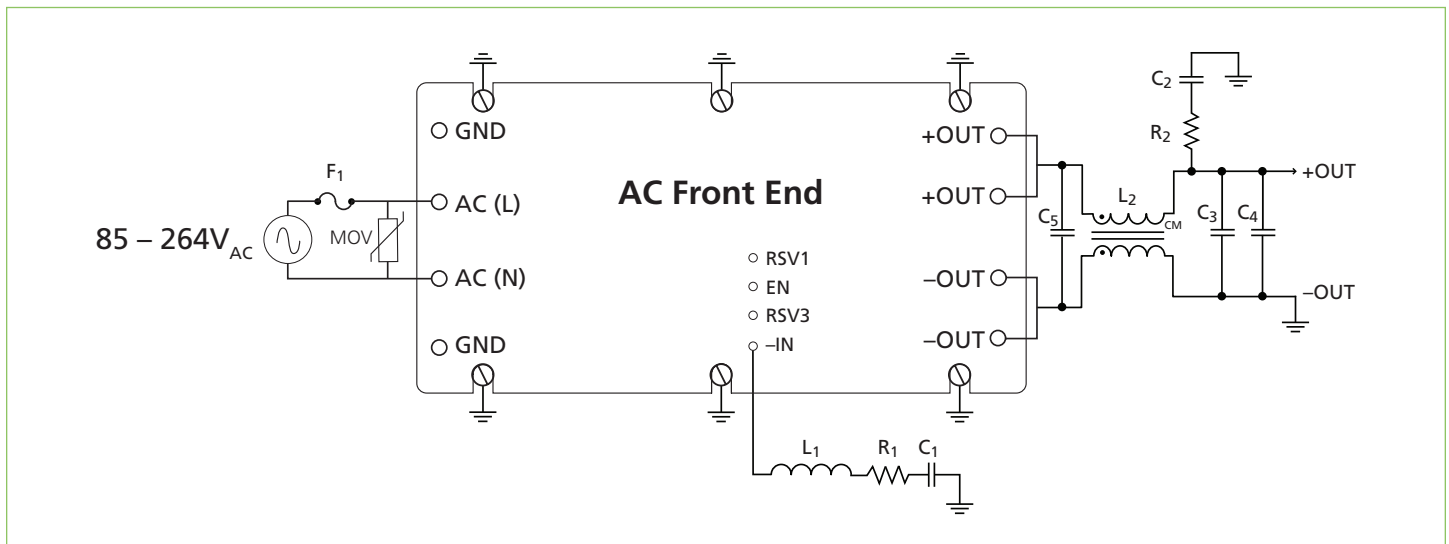

Part Number	Input Voltage	Output Voltage	Output Power	Operating Temperature
FE175D480C033FP-00	85 – 264V _{AC}	48V _{DC}	330W	–20 to 100
FE175D480T033FP-00				–40 to 100

Performance

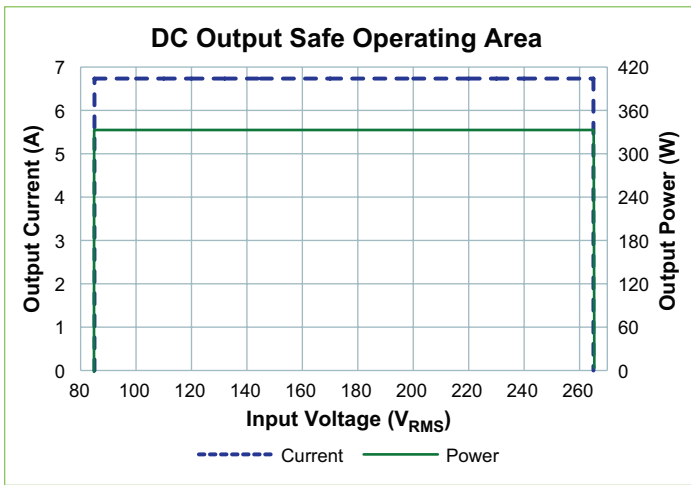

DC output safe operating area

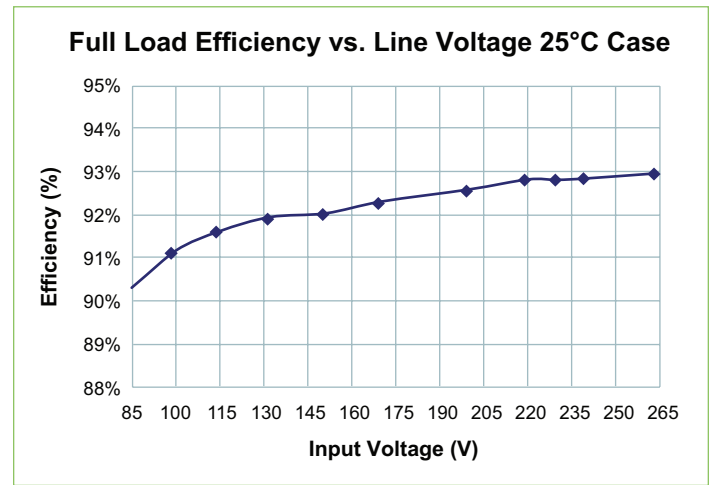

Full-load efficiency vs. line voltage, $T_{CASE} = 25^\circ C$

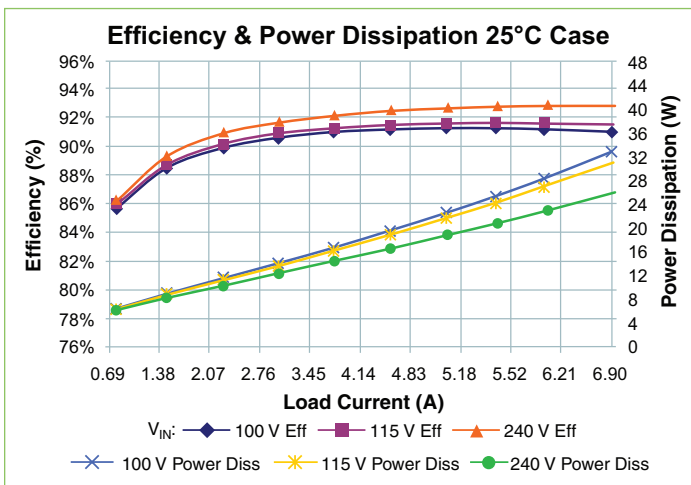

V_{IN} to V_{OUT} efficiency and power dissipation vs. V_{IN} and I_{OUT} , $T_{CASE} = 25^\circ C$

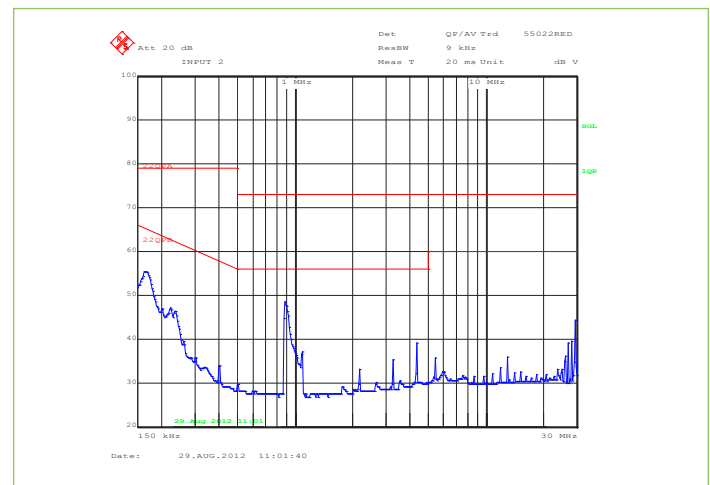

Typical EMI spectrum, quasi-peak scan, 90% load, $V_{IN} = 230V$, $C_{OUT} = 6800\mu F$

Product Dimensions

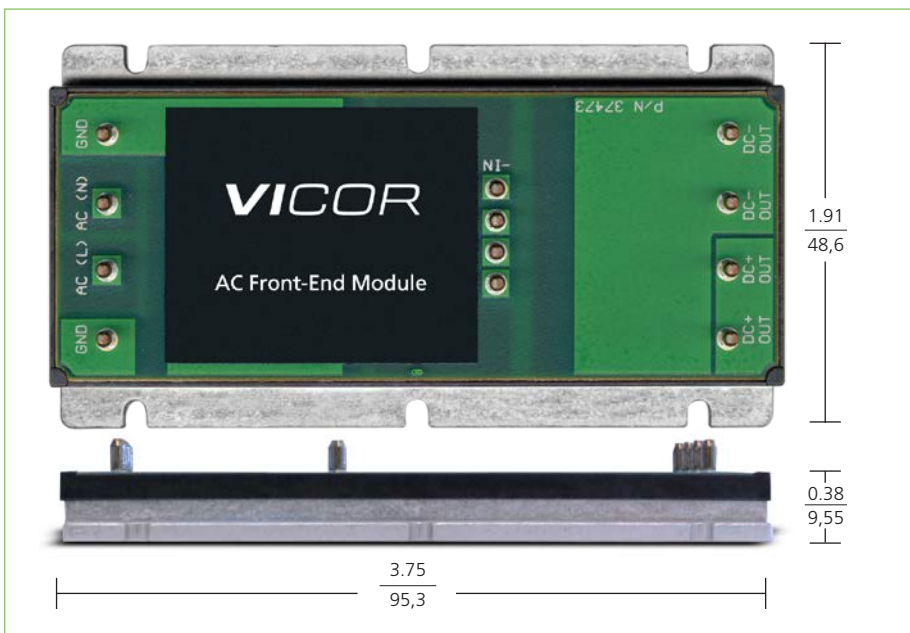

Accessories

- Common-Mode Inductor
P/N: 37052-601
- Low-profile (10 x 50mm) capacitors
P/N: 34837-108
- ThermMate Pad
P/N: 36967
- Longitudinal Heat Sink (31.7mm)
P/N: 38145
- Transverse Heat Sink (31.7mm)
P/N: 38146
- Longitudinal Heat Sink (17.7mm)
P/N: 39068
- Transverse Heat Sink (17.7mm)
P/N: 39069
- Standoffs:
See website for part numbers